

PALAN A CHAÎNE

ELECTRIQUE

RHER01-02

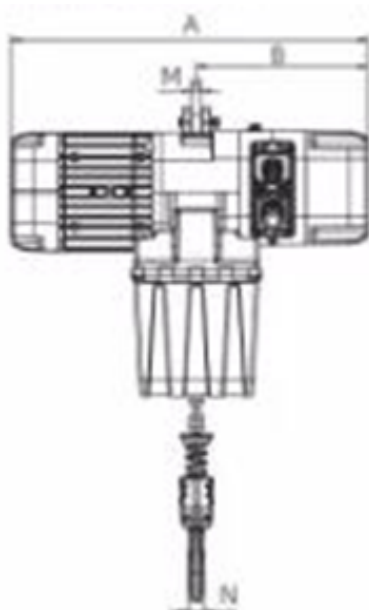
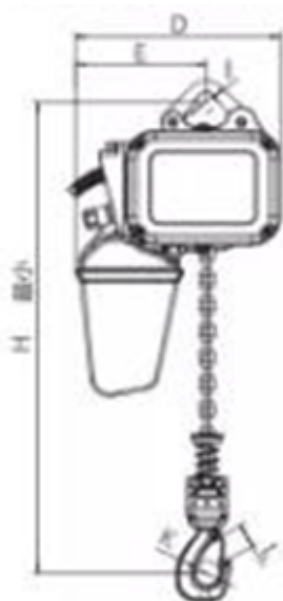

Spécification Technique

	MM
H	540
A	695
B	350
D	420
E	265
I	45
M	20
N	35
K	52
L	42

MODÈLE	RHER01-02
Charge Maximale	2.3T
Charge nominale	2T
Vitesse de levage (m/min)	6.7
Puissance Moteur (kw)	2.2
Vitesse de rotation (r/min)	1440
Classe d'isolation du moteur	F
Fréquence	50
Courant	AC380V L1 L2 L3
Contrôle voltage	AC36V
Nbre de chaîne de chargement	1